

VPV series

VARIABLE DISPLACEMENT
VANE PUMPS

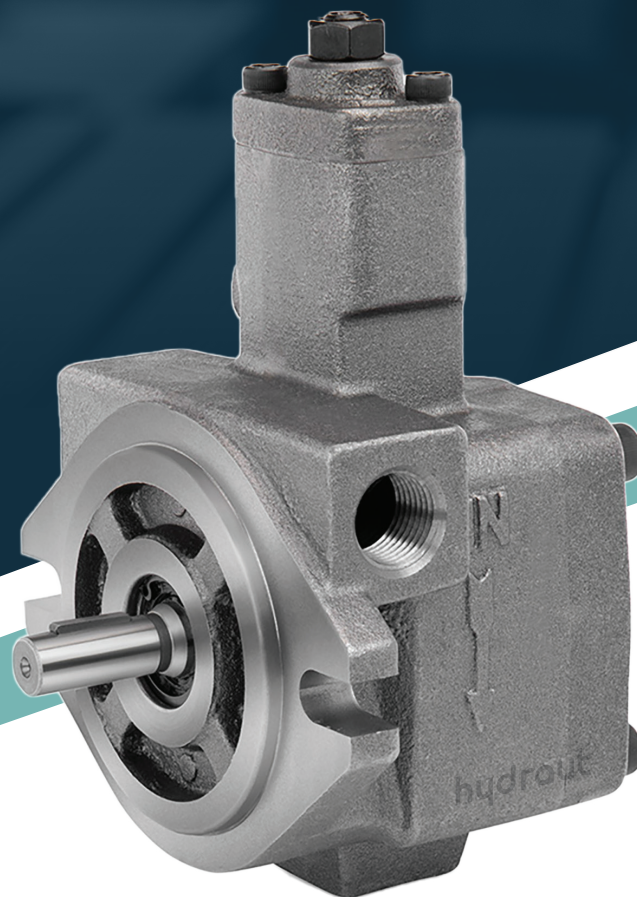

hydrait

VPV SERIES

VARIABLE DISPLACEMENT VANE PUMPS

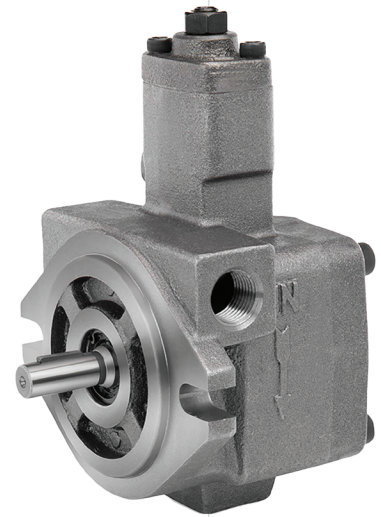
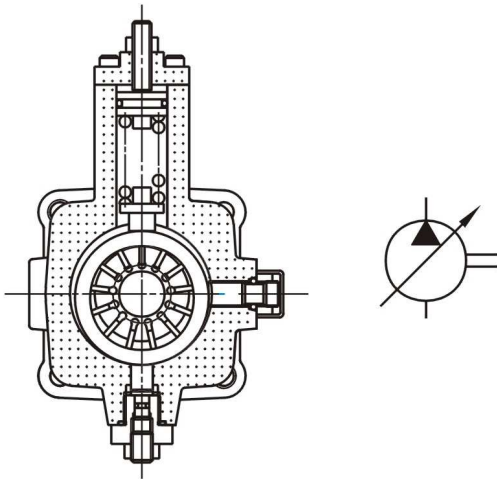

Single pumps model code

M-	VPV1	-12	-55	-1.5	-10
Prefix, fluid compatibility	Series	Outlet flow (L/min)	Operating pressure range (bar)	Input power (kW)	Design
M: with motor Omit: without motor	VPV1	8	20	0.75	-10
		12			
		15			
		20			
	VPV2	30	70	3.75	-20
		40			

Double pumps model code

VPV22	-30	-70	/-30	-55	-20
Series	Outlet flow (L/min) (shaft end pump)	Operating pressure range (bar) (shaft end pump)	Outlet flow L/min (cover end pump)	Operating pressure range (bar) (cover end pump)	Design
VPV11	8	20	8	20	-20
	12		12		
	15		15		
	20		20		
VPV22	30	70	30	70	-20
	40		40		

SPECIFICATIONS

Model	Max. Displacement (cc/rev)	Flow (0bar 1800 r/min) L/min	Operating pressure range (bar)	Speed range (r/min)	Rotation (viewed from shaft end)	Input power kW(HP)	
						1800 r/min	1500 r/min
VPV1-8-20	6.7	12	8-20	800-1800	Right hand (for clockwise)	0.29 (0.5)	0.29 (0.5)
VPV1-8-35			15-35			0.59 (1)	0.44 (0.5)
VPV1-8-55			30-55			0.87 (1)	0.59 (1)
VPV1-8-70			50-70			1.19 (1.5)	1.19 (1.5)
VPV1-12-20	8.3	15	8-20			0.37 (0.5)	0.37 (0.5)
VPV1-12-35			15-35			0.75 (1)	0.55 (1)
VPV1-12-55			30-55			1.1 (1.5)	0.75 (1.0)
VPV1-12-70			50-70			1.5 (2)	1.5 (2.0)
VPV1-15-20	11.1	20	8-20			0.5 (1)	0.55 (1)
VPV1-15-35			15-35			1.1 (1.5)	0.75 (1.0)
VPV1-15-55			30-55			1.5 (2)	1.1 (2)
VPV1-15-70			50-70			1.5 (2)	1.5 (2)
VPV1-20-20	16.7	30	8-20			0.75 (1)	0.55 (1)
VPV1-20-35			15-35			1.1 (2)	1.1 (2)
VPV1-20-55			30-55			1.5 (2)	1.5 (2)
VPV1-20-70			50-70			2.2 (3)	2.2 (3)
VPV2-30-20	22.2	40	8-20			1.1 (2)	0.75 (1)
VPV2-30-35			15-35			1.5 (2)	1.5 (2)
VPV2-30-55			30-55			2.2 (3)	2.2 (3)
VPV2-30-70			50-70			3.75 (5)	3.0 (5)
VPV2-40-20	22.2	40	8-20	1.5 (2)	1.1 (2)		
VPV2-40-35			15-35	2.2 (3)	2.0 (3)		
VPV2-40-55			30-55	3.75 (5)	3.0 (5)		
VPV2-40-70			50-70	5.5 (7.5)	4.0 (5)		

VPV

INSTALLATION DIMENSIONS

VPV1-※-※-10

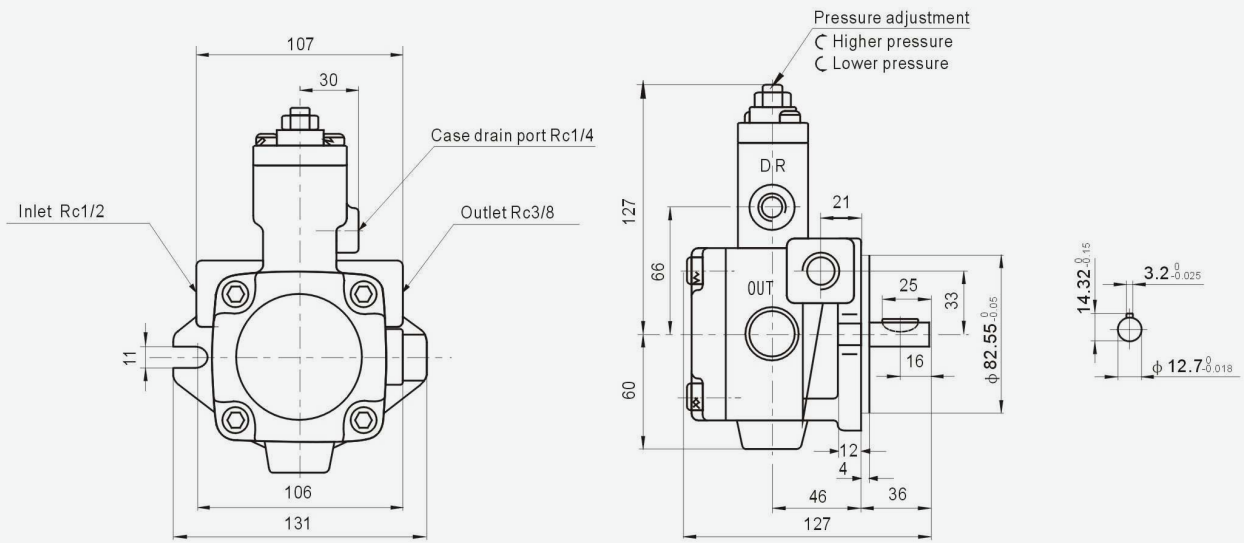

Note: No flow adjustment

VPV2-※-※-20

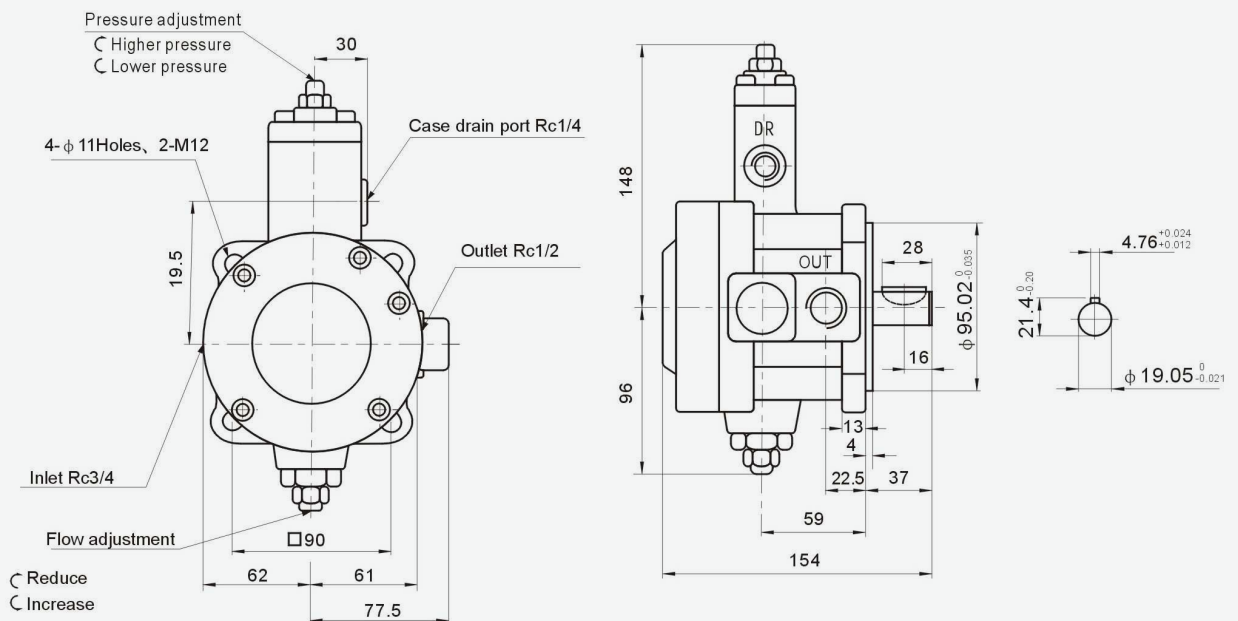

INSTALLATION DIMENSIONS

M - VPV1 - ※

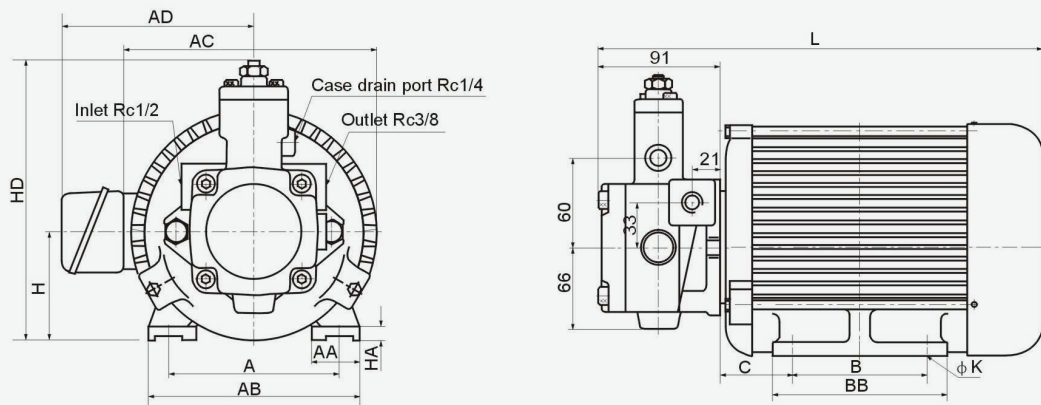

Outlet flow (L/min)	Pressure (bar)	Input power (KW)	A	AA	AB	AC	AD	B	BB	C	H	HA	HD	K	L
12	35	0.75	125	35	155	177	140	100	130	53.5	80	10	207	10	331
	55	0.75	125	35	155	177	140	100	130	53.5	80	10	207	10	331
	70	1.50	140	35	170	196	160	125	150	57	90	10	227	10	369
15	35	0.75	125	35	155	177	140	100	130	53.5	80	10	207	10	331
	55	1.50	140	35	170	196	160	125	150	57	90	10	227	10	369
	70	1.50	140	35	170	196	160	125	150	57	90	10	227	10	369
20	35	0.75	125	35	155	177	140	100	130	53.5	80	10	207	10	331
	55	1.50	140	35	170	196	160	125	150	57	90	10	227	10	369
	70	1.50	140	35	170	196	160	125	150	57	90	10	227	10	369

M - VPV2 - ※

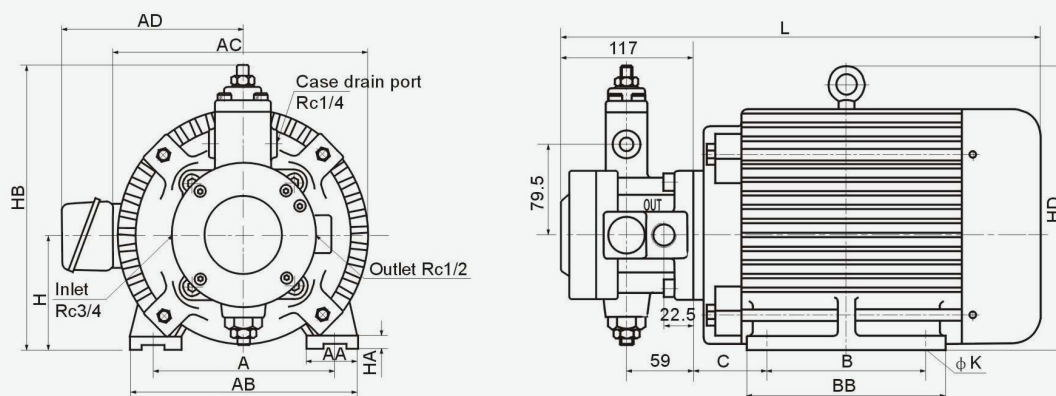

Outlet flow (L/min)	Pressure (bar)	Input power (KW)	A	AA	AB	AC	AD	B	BB	C	H	HA	HB	HD	K	L
30	35	1.5	140	35	170	196	160	125	150	57	90	10	238	-	12	395
	55	2.25	160	45	200	225	160	140	175	65	100	12	248	247	12	424
	70	3.75	190	45	228	245	180	140	175	73.5	112	12	260	265	12	447
40	35	1.5	140	35	170	196	160	125	150	57	90	10	238	-	12	395
	55	3.75	190	45	228	245	180	140	175	73.5	112	12	260	265	12	447
	70	5.5	216	45	250	270	190	140	175	77	132	16	280	310	12	452

INSTALLATION DIMENSIONS

VPV11

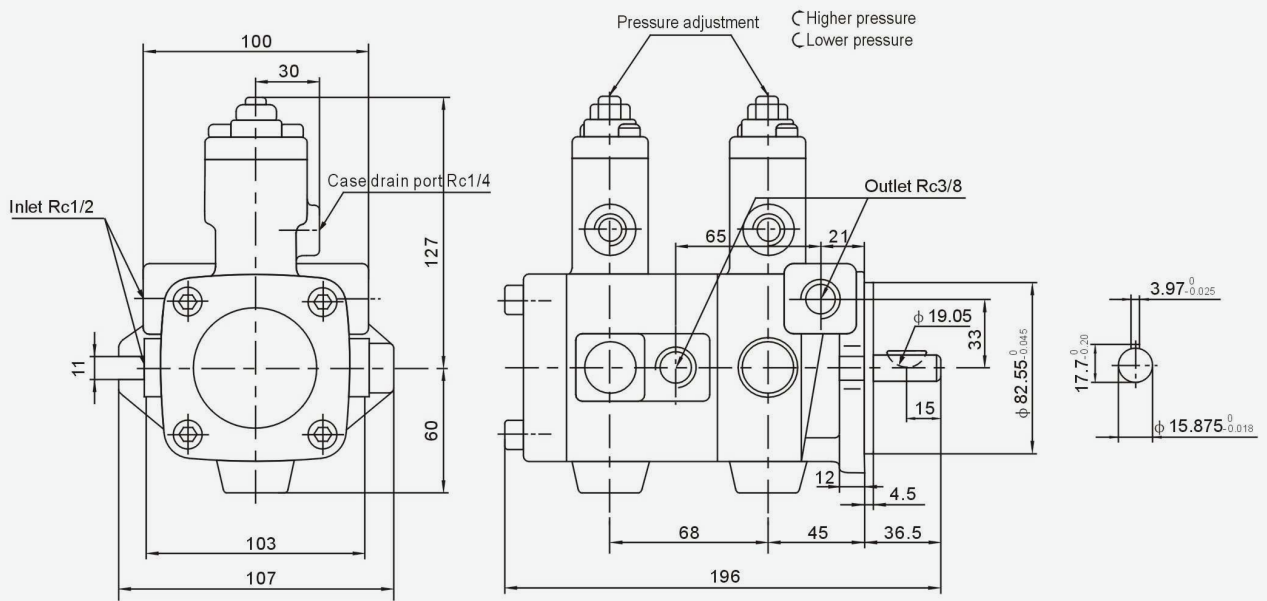

Note: No flow adjustment

VPV22

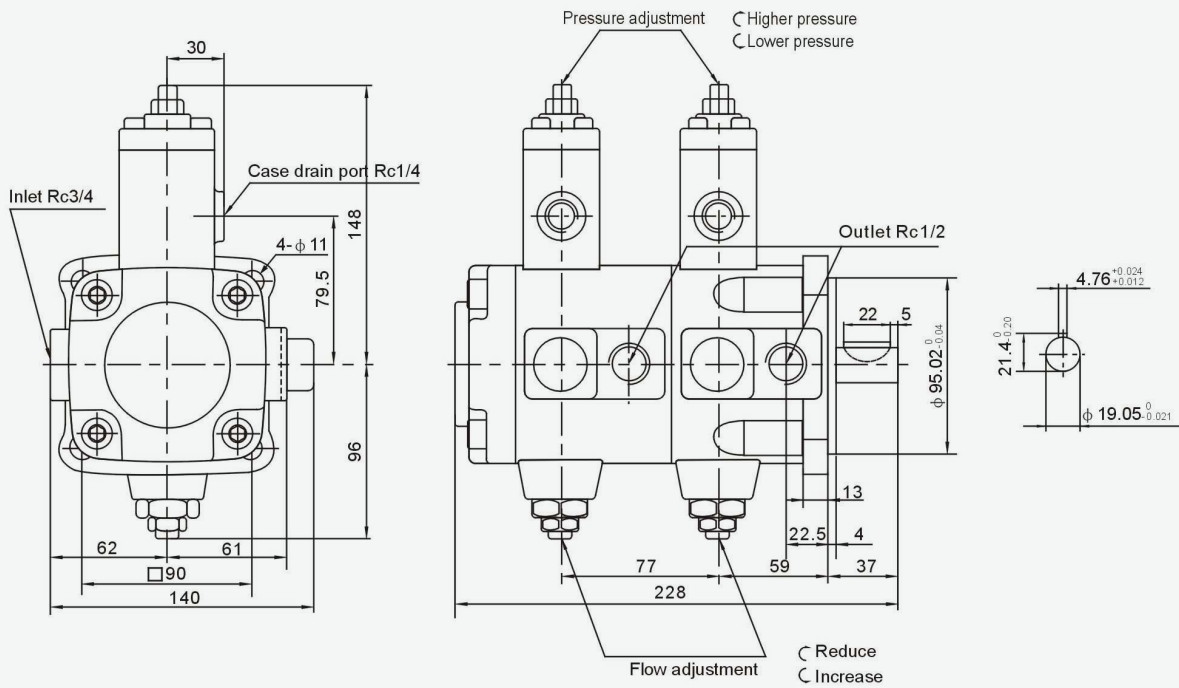

CHARACTERISTIC CURVES

VPV1-12-35

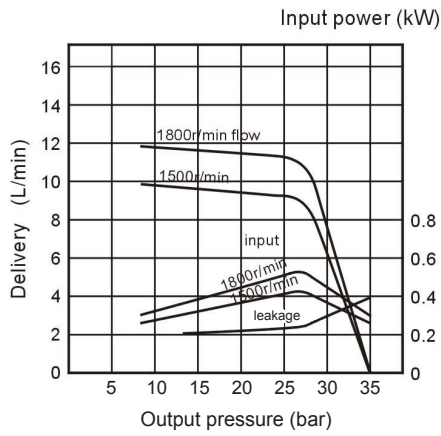

VPV1-15-35

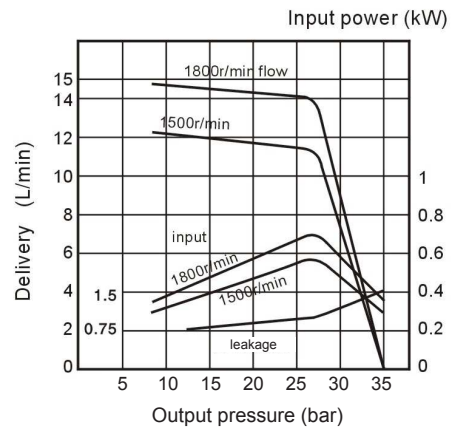

VPV1-12-55

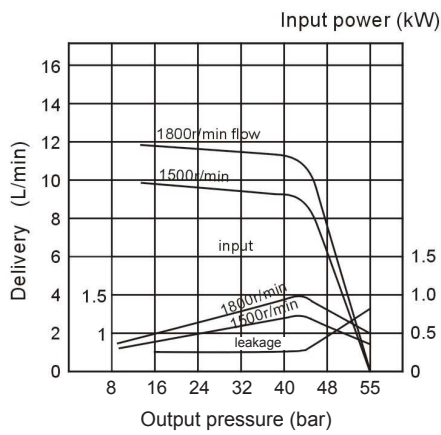

VPV1-15-55

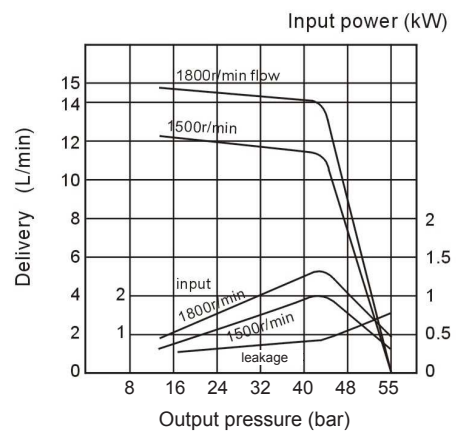

VPV1-12-70

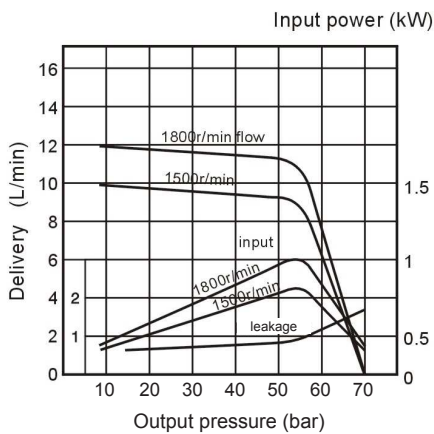

VPV1-15-70

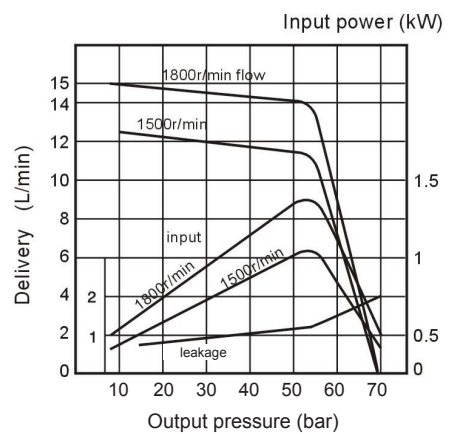

CHARACTERISTIC CURVES

VPV1-20-35

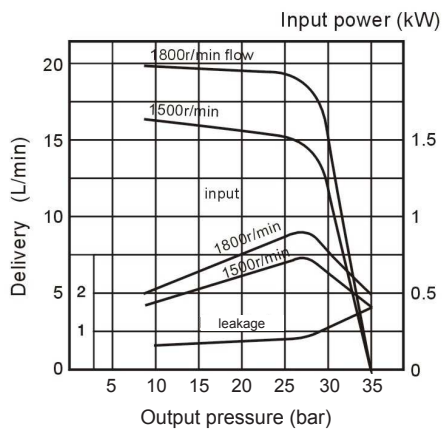

VPV2-30-35

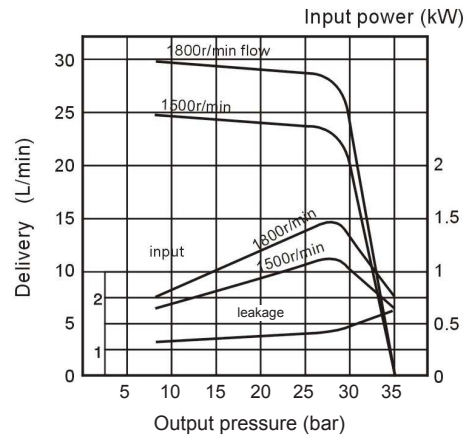

VPV1-20-55

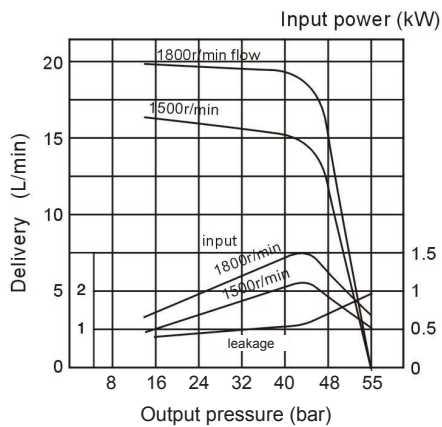

VPV2-30-55

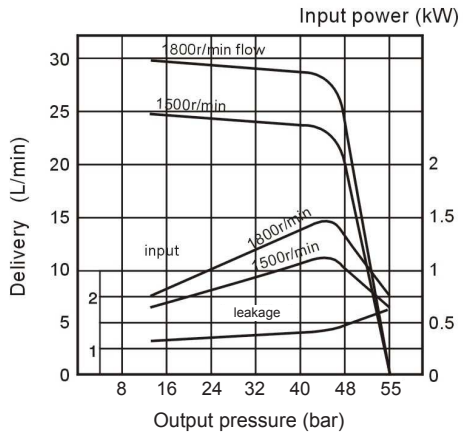

VPV1-20-70

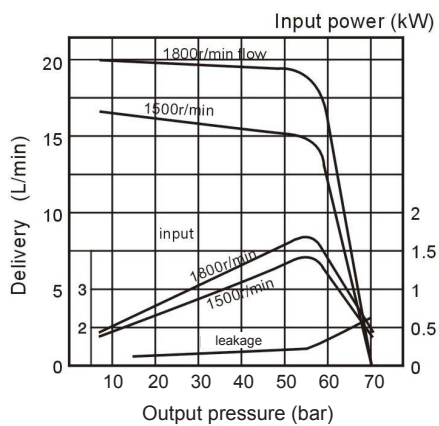

VPV2-30-70

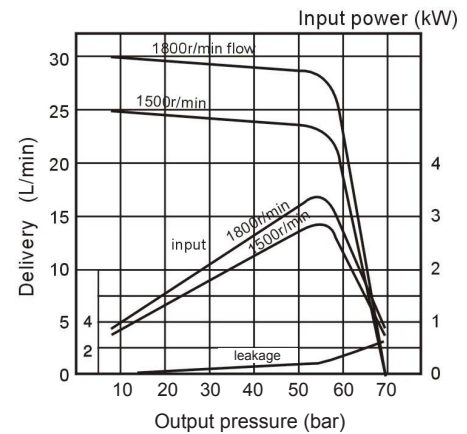

CHARACTERISTIC CURVES

VPV2-40-35

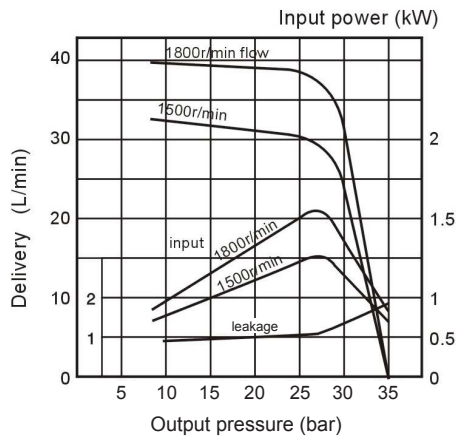

VPV2-40-55

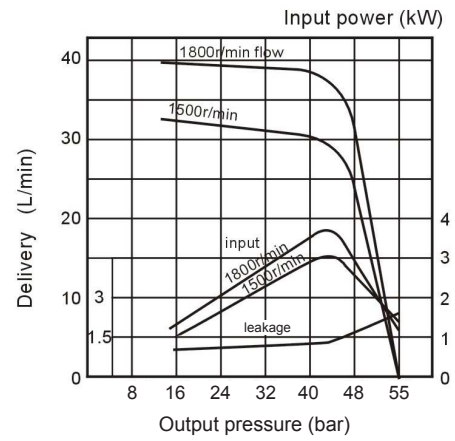

VPV2-40-70

